

# Platon® Stop Optimal

For 2 and 3 layer bonded parquet



Installation instructions for bonded parquet

*Dry and healthy buildings*



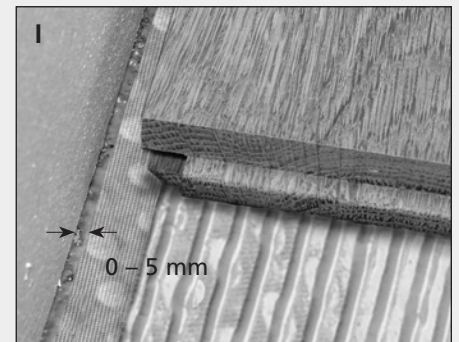
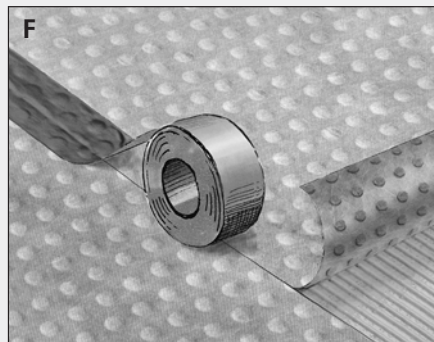
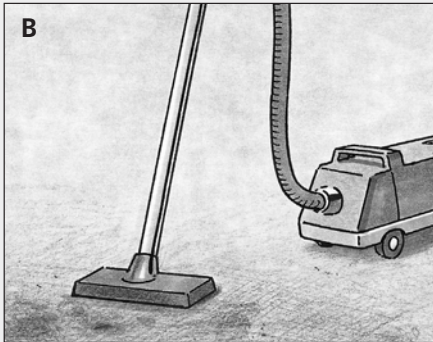
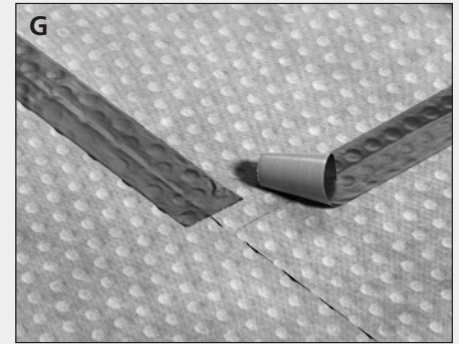
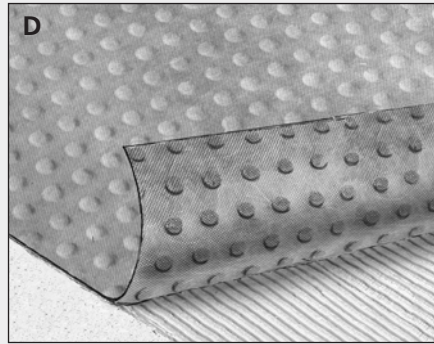
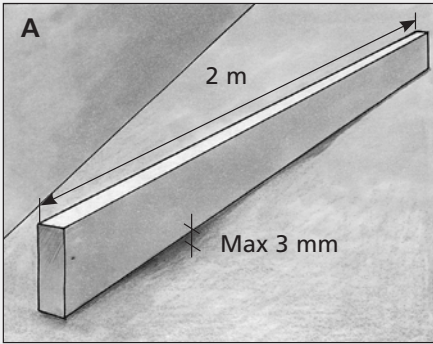

## Before laying Stop Optimal

The moisture content in concrete and special screeds should be max. 5% mc using CM method, or 95% RH using drilled hole method; for anhydrite screeds: max. 1.5% mc using CM method; for anhydrite screeds with integrated floor heating systems: max. 0.3% mc using CM method - before laying Stop Optimal and the parquet. For screeds or substrates generally with integrated floor heating systems, refer to manufacturers' information for guidance.

The substrate must be free from contact inhibiting material, such as skin (latencies) and salt residue, and removed where necessary by sanding or sandblasting, before applying MS Flex. (The substrate surface should look dry.) For substrate of lean mix or very porous material, one coat of polyurethane primer is applied to the surface. MS Flex is applied after curing the primer (3-4 hours), but within 24 hours. Platon MS Flex Parquet Adhesive must be used to apply Stop Optimal to the

substrate. Platon MS Flex is an elastic one component silane based adhesive, the only adhesive approved for use between the substrate and Stop Optimal. Use a notched trowel for liquid adhesives which spreads 850 to 1000 g/m<sup>2</sup>.

MS Flex, or similar silane based adhesive, or 2 component PU adhesive, may be used for bonding the parquet to Stop Optimal.

### A. Tolerance requirement for the substrate

Level uneven surface to meet requirements of max. 3 mm within a distance of 2 metres.

For concrete floors or similar use a cement based self-levelling screed.

### B. Cleaning substrate surface

The substrate surface should be cleaned with an (industrial) vacuum cleaner for material waste and wood shavings, etc.

### C. Applying MS Flex to the substrate

Apply MS Flex using a notched trowel for liquid adhesives which spreads 850 to 1000 g/m<sup>2</sup> over the substrate area for

one Optimal width at a time. Once each Stop Optimal width has been laid, MS Flex is applied over the substrate for the next width Optimal (see E below).

### D. Laying Platon Stop Optimal

Stop Optimal is cut to fit, and laid with the fabric on the underside solidly embedded into the MS Flex adhesive.

**NB!** The roll of Stop Optimal is "reverse" rolled up. When rolling out turn the sheet so that the felt side, with studs behind, faces downwards towards the substrate, and the printed felt side faces upwards, with "This side up" visible.

To achieve good stability, Platon Stop Optimal should preferably be laid in the cross direction to the intended parquet, but may be laid in the same direction as for intended 3 layer parquet.

### E. Installation of each width of Stop Optimal

The correct length of Stop Optimal is cut to size. Position Optimal initially, and then readjust alignment by lifting one end, pulling lightly, and then

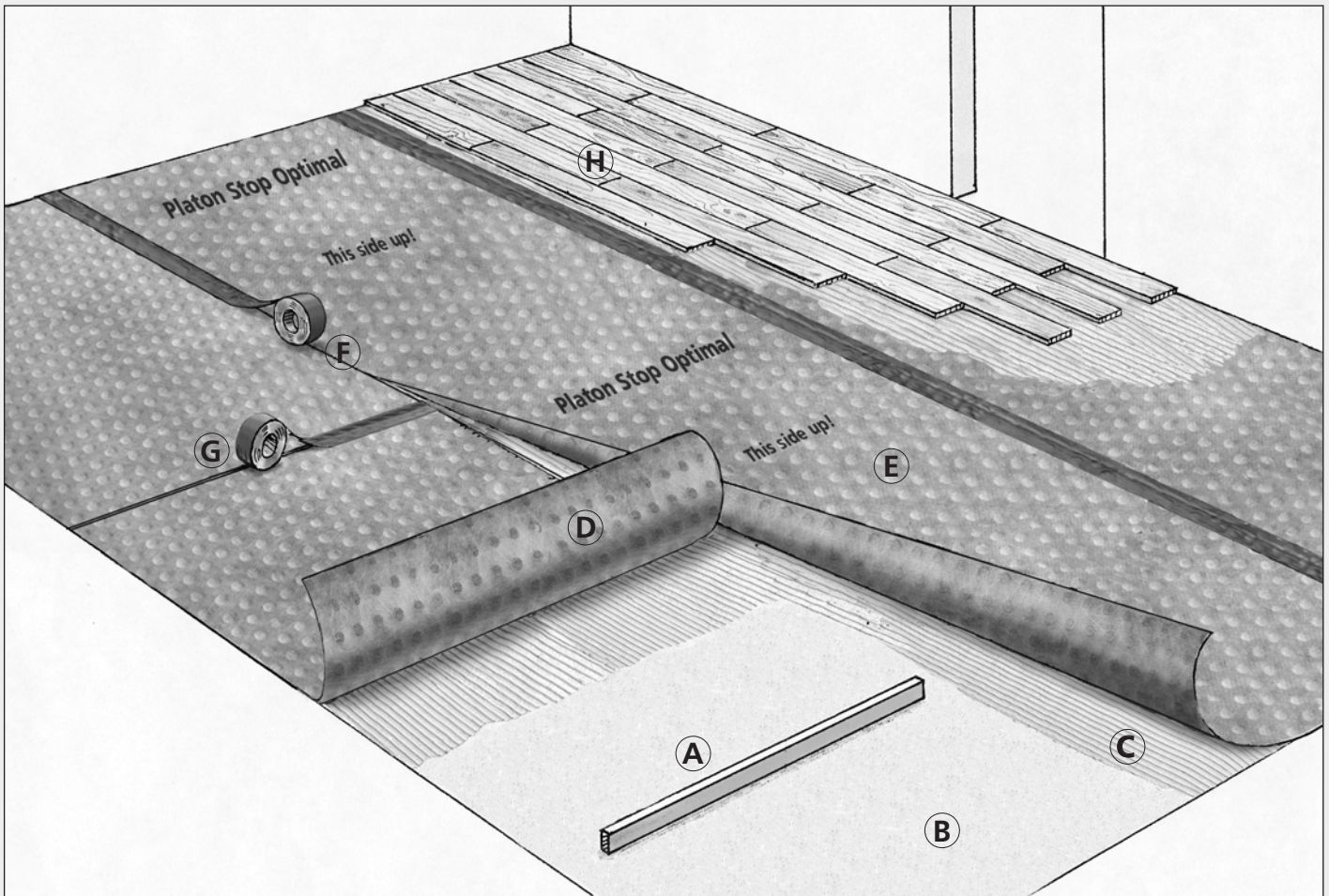

placing the tensioned membrane more precisely. Solidly embed the anchoring fibre fabric on the underface of Stop Optimal into the MS Flex adhesive, so that its entire surface is bonded. Work Stop Optimal into the adhesive, in one direction, using a float or screed trowel, or roller. Installation is easier with two people working together. The edges of Stop Optimal rolls are cut to fit and placed edge to edge. Then seal the joint between this Optimal width to the previous one (see F below), and then apply MS Flex adhesive for the next Optimal width before laying that width.

#### F. Longitudinal joints

The rolls widths of Stop Optimal are laid edge to edge in the joint and fixed with MS Flex adhesive. Immediately after installation of each width of Stop Optimal, the joint to the previous width is sealed with Platon Stop Tape, supplied with each product roll, width 75 mm. The Stop Tape is laid along the joint, working from one end and covering each roll width equally. Stop Tape should not be stretched during application, but (after the whole tape length has been applied) be pressed firmly against the surface of Stop Optimal using hand pressure or similar.

No other tape is recommended or approved by Isola for use in joints or details with Platon Stop.

#### G. Transverse joints

Roll ends of Stop Optimal are laid edge to edge and the joint sealed with Stop Tape as in F above. Care should be taken to seal the junction between longitudinal and transverse joints.

#### H. Laying the parquet

Due to curing time for the MS Flex adhesive layer between substrate and Stop Optimal, laying of the parquet may only be commenced a minimum 6 hours after the installation of Stop Optimal. Protect against mechanical loads to avoid loosening Stop Optimal from the substrate or other damage. Platon MS Flex or alternative adhesive is applied in a single process continuously over an area appropriate for the adhesive's "open time", with a suitable notched trowel, and the parquet laid (refer to manufacturer's information for guidance). For suitable parquet types, see back page.

For larger room dimensions than 15 m, expansion joints should be inserted into the parquet layer. (Platon Stop Optimal should be cut along the line of expansion joints.)

#### I. Detail at floor/wall junction

Stop Optimal may be laid with spacing from 0 to 5 mm against walls.

Optimal is designed for normal moisture in concrete and other substrates, not damp problems. There is generally no specific requirement for venting along walls, but venting may be advisable in some cases. The MS Flex adhesive must not block the air gap against the wall. For heating systems in the substrate, a ventilating skirting board is recommended for better equalization of damp pressure, when the heating system is switched on and off. Isola offers other damp proofing products for damp problems in concrete substrates. Ask your distributor for more information.

The parquet should be laid allowing for expansion against walls, normally 5 to 10 mm. Refer to the manufacturer's information for guidance.

# Platon® Stop Optimal



## Parquet suitable for bonding

2 layer and 3 layer parquet are suitable for laying on Platon Stop Optimal.

2 layer parquet should be of good quality and thickness to provide satisfactory stiffness. Massive parquet (one layer) is not suitable for laying on Platon Stop Optimal (ask your distributor for more information).

The parquet should be laid allowing for expansion against walls, normally 5 to 10 mm. Refer to the manufacturer's information for guidance.

For larger room dimensions than 15 m, expansion joints should be inserted into the parquet layer (refer to manufacturer's information for guidance). Platon Stop Optimal should be cut along the line of expansion joints.

## Platon Stop Optimal

The roll of Stop Optimal should be acclimatized to room temperature before installation. Any floor heating should be switched off and the floor temperature allowed to fall to room temperature, but not below 15°C, before installing Optimal. The room air should be at minimum temperature 16°C and maximum humidity 65% RH before the start of and during installation of Stop Optimal.



ISO 9001



Manufactured by Isola as, Platon Factory, N-3678 Notodden

Stop Optimal should preferably be laid in the cross direction to the intended parquet to achieve good stability of the finished floor, but may be laid in the same direction as for intended 3 layer parquet. For 2 layer parquet, Optimal should always be laid in the cross direction of the intended parquet.

**NB!** The roll of Stop Optimal is "reverse" rolled up. When rolling out turn the sheet so that the felt side, with studs behind, faces downwards towards the substrate, and the printed felt side faces upwards, with "This side up" visible.

Stop Optimal may be laid with spacing from 0 to 5 mm against walls.

## Platon Stop Tape

Platon Stop Tape has very good adhesion and withstands alkaline damp. No other tape is recommended or approved by Isola for use in joints or details with Platon Stop.

## MS Flex

Platon MS Flex is an elastic one component silane based adhesive, the only adhesive approved for use between the substrate and Stop Optimal. Use a notched trowel for liquid adhesives which spreads 850 to 1000 g/m<sup>2</sup>.

MS Flex, or similar silane based adhesive, or 2 component PU adhesive, may be used for bonding the parquet to Stop Optimal.

The substrate must be free from contact inhibiting material, such as skin (latencies) and salt residue, and removed where necessary by sanding or sandblasting, before applying MS Flex. (The substrate surface should look dry).

For substrate of lean mix or very porous material, one coat of polyurethane primer is applied to the surface. MS Flex is applied after curing the primer (3-4 hours), but within 24 hours.

Minimum curing time for the MS Flex adhesive layer between substrate and Stop Optimal is 6 hours, before working on Optimal and laying the parquet. Protect against mechanical loads to avoid loosening Stop Optimal from the substrate or other damage. MS Flex withstands frost but should be stored in room temperature before use.

## Thermal insulation

Thermal insulation sheets must not be laid above the substrate, but where appropriate should already be in place within the substrate.

## Floor heating systems

Heating systems must not be laid above the substrate, either below or above Stop Optimal.

Stop Optimal may be laid on substrates containing heating pipes or cables. The heating system should not be switched on before the adhesive for the parquet has properly set and cured (normally at least 7 days). Refer to floor manufacturer's information for guidance. Generally, the control temperature should be raised from room temperature by 5°C intervals per 24 hours to a maximum of 30°C. A ventilating skirting board is recommended for better equalization of damp pressure, when the heating system is switched on and off.

Isola offers other damp proofing products for damp problems in concrete substrates. Ask your distributor for more information.

Dry and healthy buildings

## Isola as

N-3945 Porsgrunn  
Tel: +47 35 57 57 00  
Fax: +47 35 55 48 44  
E-mail: [isola@isola.com](mailto:isola@isola.com)

[www.isola.com](http://www.isola.com)