

Platon Flexi

Lateral force absorber for tiled floors

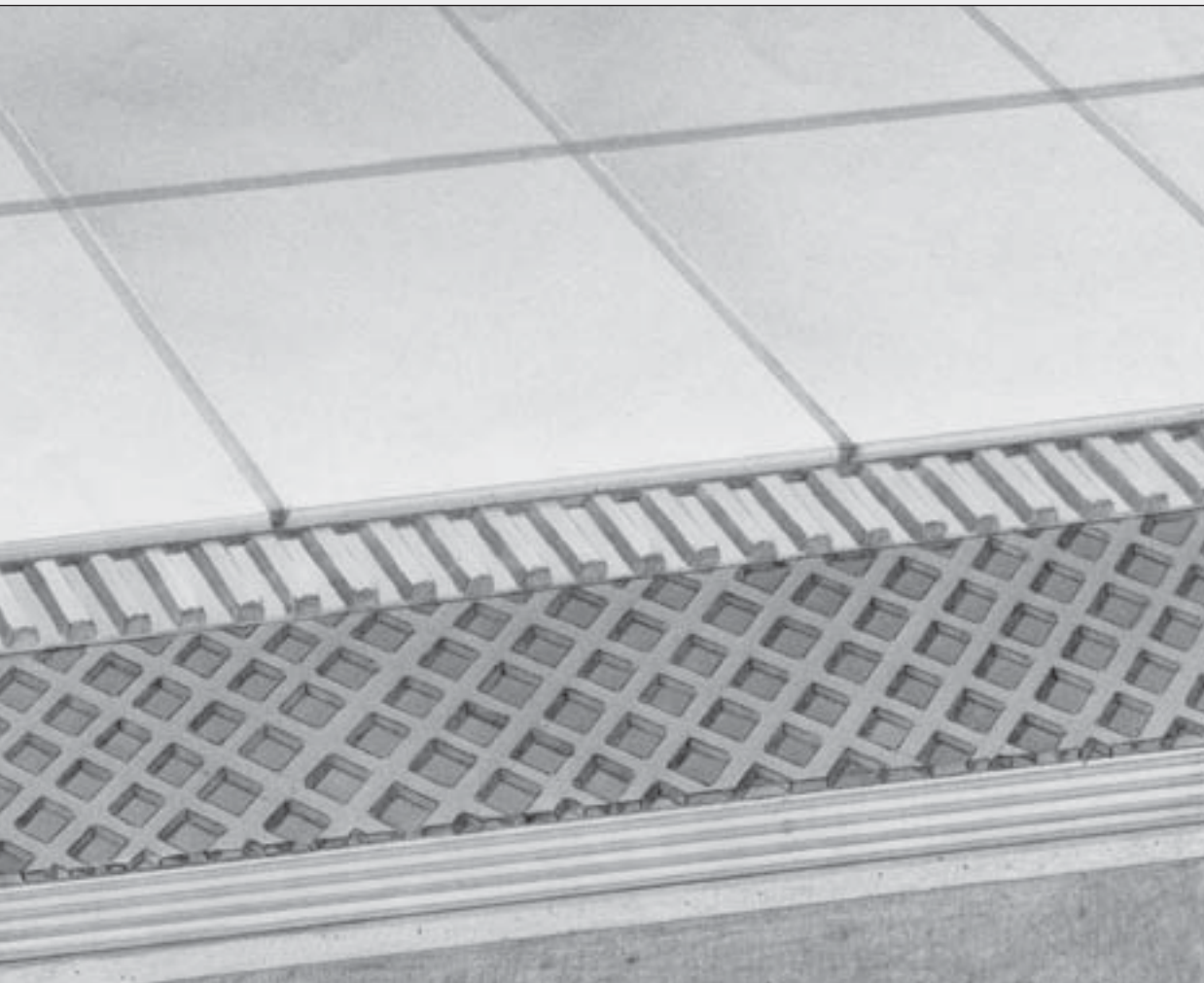

Installation instructions for use internally on floors
not exposed to water

Dry and healthy buildings



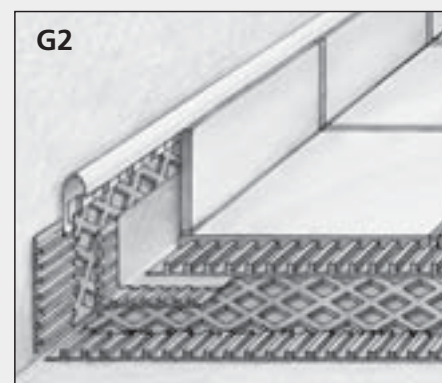
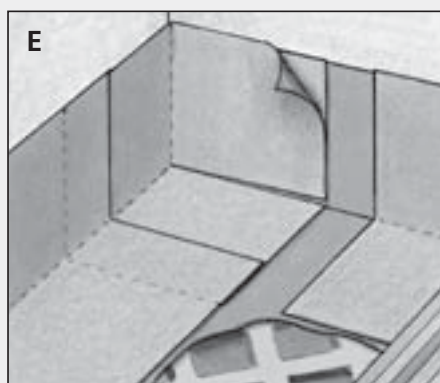
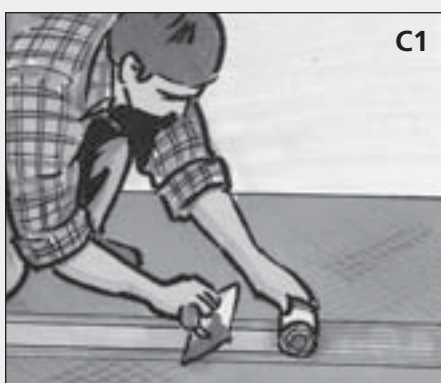
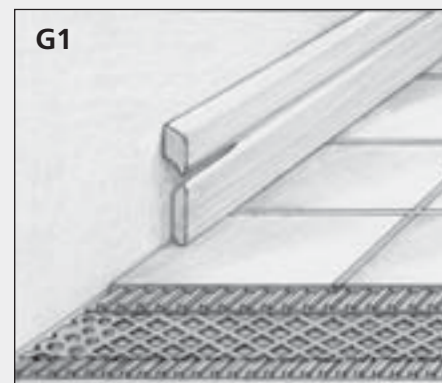
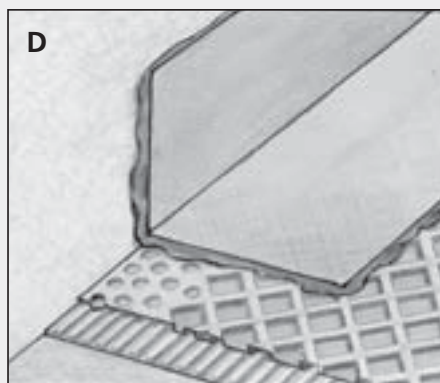
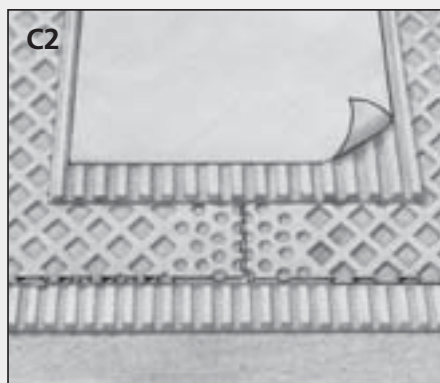
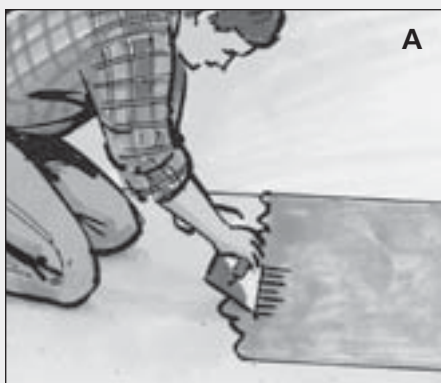

A. Preparation

The substrate must be even, adequately load bearing, and free from material which may prevent bond of the adhesive. The tile adhesive must bond to the substrate, and anchor mechanically to the fibre fabric on the underside of the Platon Flexi.

There is no limit for moisture content in concrete and special screeds, before Flexi and tiles may be laid, but the surface should be hard enough to walk on. For anhydrite screeds the moisture content should be max. 1.5% mc using CM method; for anhydrite screeds with integrated floor heating systems; max. 0.3% mc using CM method - before laying Flexi and tiles.

The type of bonding adhesive used to apply Platon Flexi depends on the type of substrate. The tile adhesive must therefore match with the substrate.

Normally the best results are achieved with thin-bed mortar; flex mortar or fluidised bed mortars that are hydraulic setting. The thin-bed mortar or fluidised-bed mortar is applied to the substrate using a 4 x 4 mm notched trowel over the substrate area for one Flexi width at a time.

B. Installation

The correct length of Platon Flexi is cut to size. Position Platon Flexi initially, and then readjust alignment by lifting one end, pulling lightly, and then placing the tensioned membrane more precisely. Solidly embed the anchoring fibre fabric on the underface of Platon Flexi into the tile adhesive so that its entire surface is bonded.

Work Platon Flexi into the adhesive, in one direction, using a float or screed trowel, or roller. Installation is easier with two people working together.

The edges of Flexi rolls are cut to fit and placed edge to edge. Then seal the joint between this Flexi width to the previous one (see C below), and then apply tile adhesive for the next Flexi width before laying that width.

C. Joints

The joint strip, Platon Flexi J, is placed over Flexi which has been placed edge to edge in the joint and fixed with tile adhesive. Joints are sealed with Flexi J immediately after installation of each length of Flexi. It is advisable to apply the tile adhesive in a single process using a 4 x 4 mm notched trowel.

Install Platon Flexi J ensuring full coverage of adhesive between the surfaces of flexi and Flexi J. Flexi J is installed edge to edge at junctions and roll ends. Observe the open time for the adhesive.

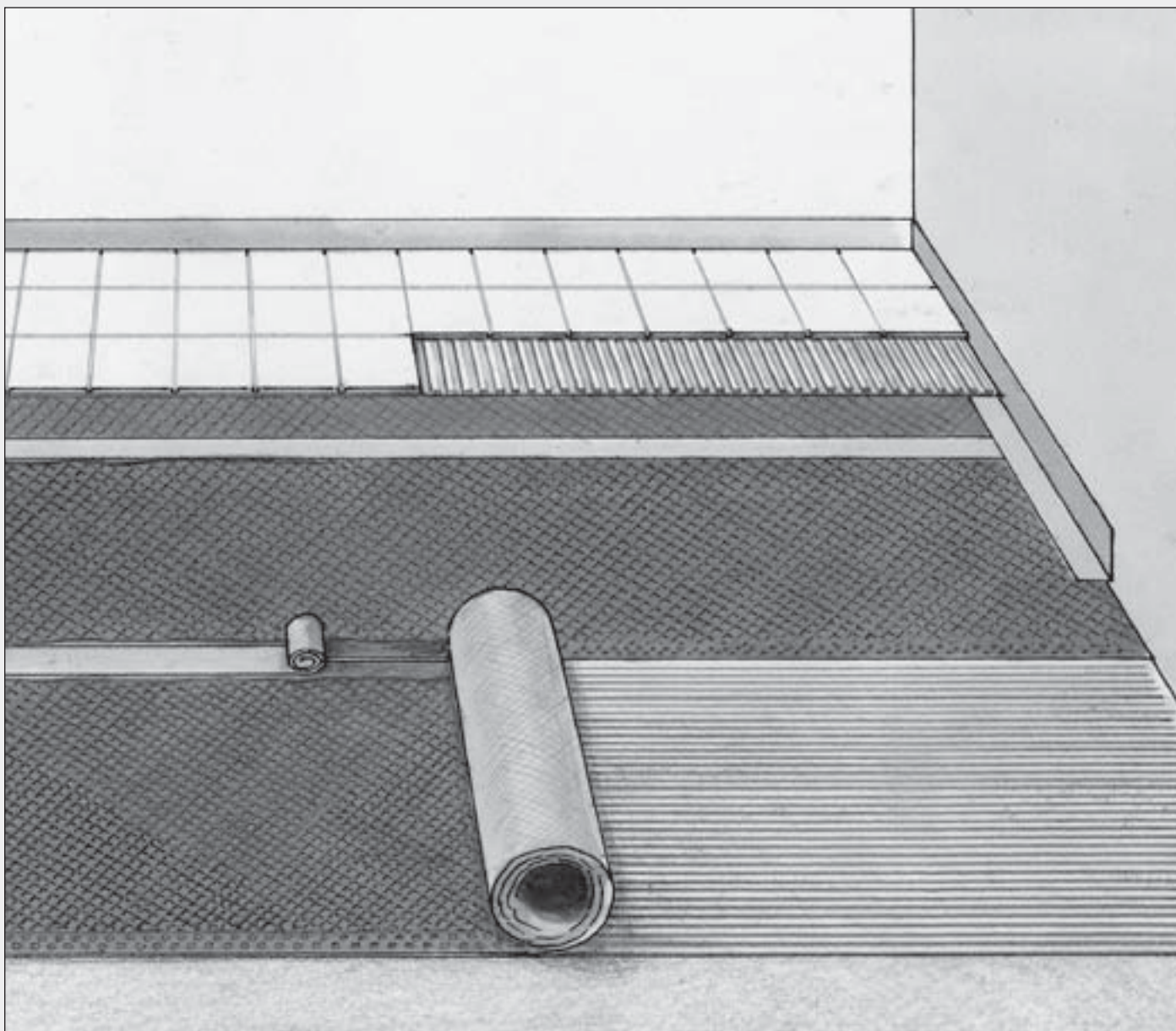

Platon Flexi should be cut along the line of expansion joints (covering of a large area should be divided into segments in accordance with the specification in each case).

D. Wall/Floor junction

Where Platon Flexi is sealed against the wall, use the joint strip, Platon Flexi J, as wall/floor junction with tile adhesive behind Flexi J to the wall and Flexi.

E. Corners

External and internal corners may be cut to size using the joint strip, Platon Flexi J. Ensure full coverage with tile adhesive. Overlap Flexi J where suitable.

F. Tile installation

Tiles may be laid without delay after the installation of Platon Flexi, using the thin-bed method, in stages over one Flexi width at a time (before applying the tile adhesive for the next Flexi width. Alternatively, if installed continuously over the whole floor area, Platon Flexi must be protected against mechanical loads to avoid loosening it from the substrate or other damage, until the tile adhesive between substrate and Flexi has set (refer to manufacturer's information for guidance), prior to laying tiles. It is advisable to fill the studs completely with tile adhesive in a suitable area, and apply the tile adhesive using a notched trowel suitable for the tile size and type. Install the tile ensuring full coverage of adhesive. Observe the open time for the adhesive.

G. Venting

The air gap on the underside of Platon Flexi allows water vapour pressure to be equalised to the room.

G1. Option 1

Install Platon Flexi and the tiles approximately 5 to 10 mm from the wall and install Platon Ventilated Skirting Board to allow communication between the air gap and the room.

G2. Option 2

Install a strip of Platon Flexi on the wall using tile adhesive and seal the junction with Flexi J. A profile can be installed above the skirting tile, with a distance of 2 mm to the top edge of the tile, to allow communication with the air gap of Platon Flexi.

Platon Flexi



Lateral force absorption (separation)

Platon Flexi provides lateral force absorption so that transfer of stresses from the substrate to the tiled surface is prevented. Thus any crack in the substrate, caused by movement, is neutralized, and bridged, not transmitted through to the tiles. Flexi is able to bridge cracks of at least 2 mm.

Material

Platon Flexi is a polypropylene membrane with a specially designed structure of square studs, each cut back in a dovetail configuration or undercut, with an anchoring fibre fabric laminated to its underside. Platon Flexi is approximately 3 mm high.

Material properties for durability in aggressive environments

Platon Flexi does not rot, and is highly resistant to solutions containing salts, acids, and alkalis, as well as many organic solvents, alcohol and oils. Its imperviousness to steam is very high. The material is safe for use in food and related industries. It must be verified that substrates, which are to be covered by Platon Flexi, are clean, even, and adequately load bearing.

Contact inhibiting surfaces must be removed prior to the installation of Platon Flexi.

Requirement of tile and substrate

The contact surface of Platon Flexi amounts to approximately 50% of the total surface area. This may reduce the load bearing capacity of constructions, and limit point loads. Select appropriate tile quality, thickness and size.

Tiles should have a minimum size of 50 x 50 mm.

Platon Flexi acts as a damp proof membrane, particularly important for moisture sensitive materials such as natural stone.

Bond inhibiting surfaces must be removed and the substrate levelled, if necessary. If in doubt, test the compatibility of the adhesive with the substrate. Concrete and similar surfaces which are hard enough to walk on may receive Flexi and tiles without delay. Laying on other substrates are subject to limits for moisture content, see page 2, part A. Porous and uneven surfaces may require sanding and/or priming. The heating in floors with heating systems should not switched on until minimum 7 days after installation of Flexi and tiles, the control

temperature being raised from room temperature by 5°C intervals per 24 hours to a maximum of 40°C.

Heating systems may be laid and bonded into the construction, preferably between substrate and Flexi, provided they are approved for use against flammable surfaces (low voltage and some 230 volt systems are approved).

Substrates of plywood, OSB and chipboard should be of high quality or exterior grade with tongue and groove glued joints, and suitable thickness to ensure stability on the supporting construction. Screw the sheets to the supporting construction at suitable spacing. Allow minimum 10 mm at transitions to other floor constructions.

Timber floor boards or planks should be levelled to a minimum of the top of the curvature of the boards, preferably 5 mm above. Alternatively, substrates of timber boards may be stabilised by laying plywood, OSB or chipboard following the levelling of the boards to the top of the curvature, and screwing through to the supporting construction.

Isola offers other damp proofing products for damp problems in concrete substrates. Ask your distributor for more information.



ISO 9001



Platon Flexi components	Dimension
Platon Flexi	1,00 x 10 m: 10 m ²
	1,00 x 25 m: 25 m ²
Platon Flexi J	0,15 x 10 m: 10 m ²
	0,15 x 25 m: 25 m ²
Damp proof joint strip made of polyethylene with fibre fabric laminated on both faces, for sealing of joints in floors not exposed to water. Tile adhesive is anchored mechanically in the fibre structure.	

Dry and healthy buildings

Isola as

N-3945 Porsgrunn
Tel: +47 35 57 57 00
Fax: +47 35 55 48 44
E-mail: isola@isola.com

www.isola.com