



Triton Dual Assist Pump System

System components:

- 2 x 240v manual pumps
- 2 x non return valves
- Sump liner
- Dipster control mechanism
- Dual Assist Control Panel



Where two pumps are installed in a single sump then the Dual Assist Control Panel will activate both pumps alternately and also, in times of high water ingress, will activate both pumps to operate simultaneously.

The Dual Assist Control Panel is provided with integral high level alarm and monitoring capabilities to monitor the number of activations and length of run times for each of the two main pumps. Both pumps and the high level alarm are operated by the control panel via float switches located in the sump.

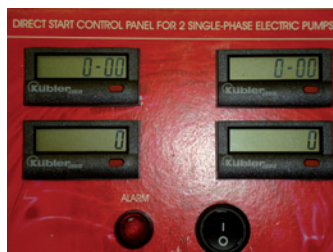

Features

- Dual pump operation
- Electronic control panels
- Very low voltage inputs for external control
- Mains LED
- Motor operating LED
- Motor protected LED
- Min/Max alarm lamp
- Auto-Off-Manual selector switch (Manual not latched)
- Adjustable current potentiometer for different pump sizes
- Motor fuses

- Aux. protection fuses
- Door interlock switch
- Plastic enclosure
- IP50 protection

Plus

- Battery operated hours run
- Battery operated counter
- 2 x single float operation (differential float) – one for each pump
- Alarm outlet (MA/1 or equivalent)
- Alarm operated by alarm float and panel trip

Pumps

2 x Tsurumi OMA Manual pumps are supplied as part of the system. The manual pumps are directly operated by the control panel and float control mechanism. Each Tsurumi OMA pump to be connected to its own discharge outlet pipe, and incorporate a non return valve (included).

Each Tsurumi OMA pump:

- Maximum head 7.5m
- Pump capacity 195 l/ min
- Will pump @ 120l / min to 4m head

Dipster level control mechanism

The Dipster is a robust level control switch, designed to operate in wet environments which could lead to early failure of conventional switches. The switch works by displacement, not floatation, and therefore has a highly stable weighted sensor arrangement that resists water movement and remains reliable even in turbulent conditions.

The working length and adjustable top sensor position make it easy to set the operating levels on site.

General Characteristics:

- Universal displacer type level switch
- C/O contacts for filling or emptying duties
- Compact displacers for confined spaces
- Nylon coated Stainless Steel cable
- No sliding floats to jam
- Fully adjustable on site
- Corrosion resistant materials throughout
- Switch terminals and cable resin potted
- IP67 for wet environments



Technical Details:

MODEL	CODE	Rating	Cable	Sensor Length	Max Temp
Dipster P05/0.6	ES4D-P05X06DIP-A1N	15A @ 240V	3c PVC – 5m	0.6m	65 °C

Note:

The dual assist panel can be purchased separately to upgrade an existing system, but please specify the existing type of pump currently in place before placing an order as modification to the panel may be required. Please allow up to 10 working days for delivery.

Installation guidelines

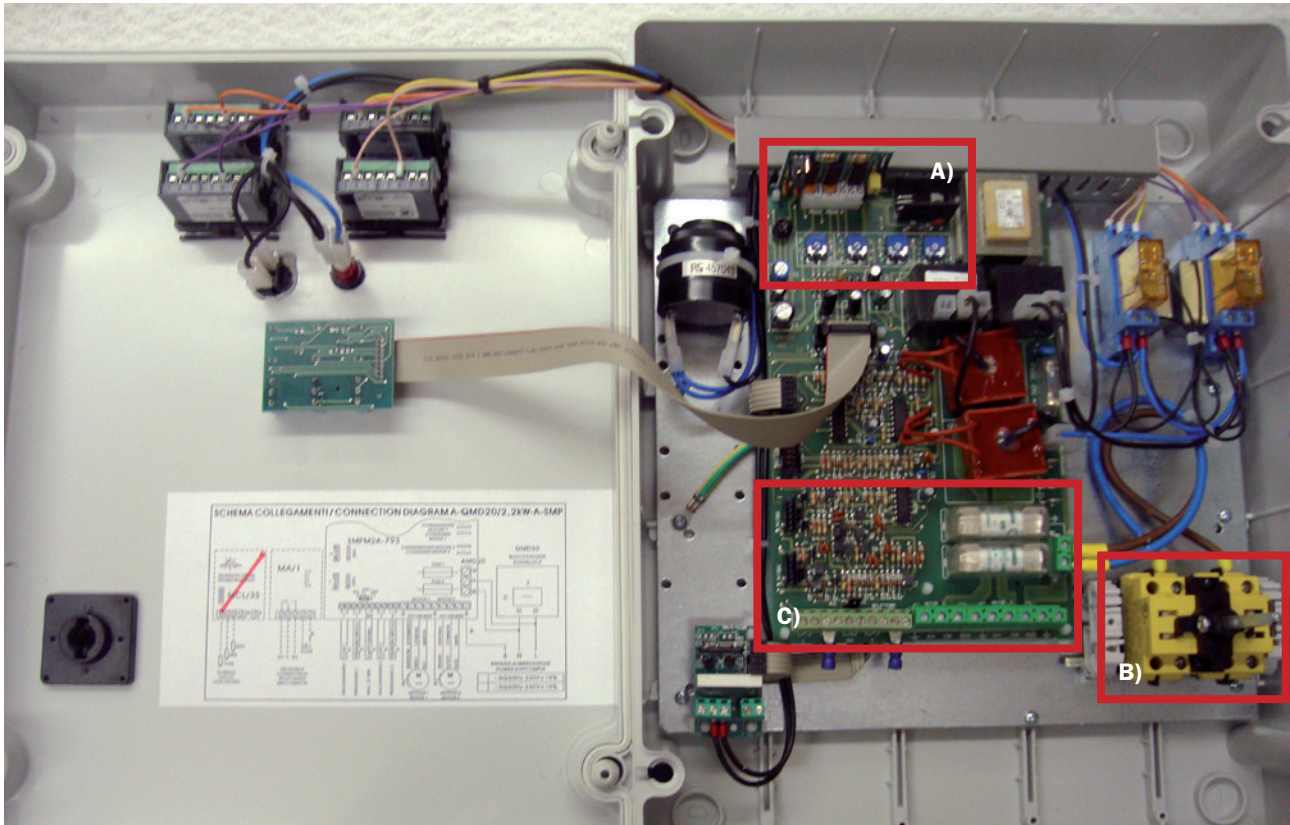

Before putting the panel into service, it is essential to check that it has been correctly set up for the installation in hand. These checks must include:

A)

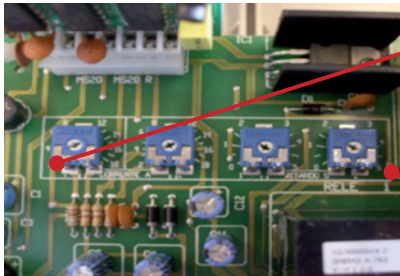

Motor current overload trimming potentiometer
Set values to motor rated current plus 10% for each pump

Start up overload delay trimming potentiometers
Set values to 4s

B)

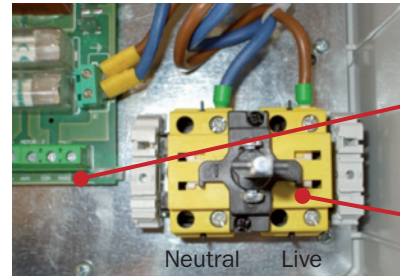

Input Connections

Earth Connection

Isolator Inputs
Neutral - Live

C) Pump and float connections

Float Inputs
1 - 2 Single float switch
3 - 4 Linked
5 - 6 Leave empty
7 - 8 2nd float switch
9 - 10 Linked

Leave jumper in NO position

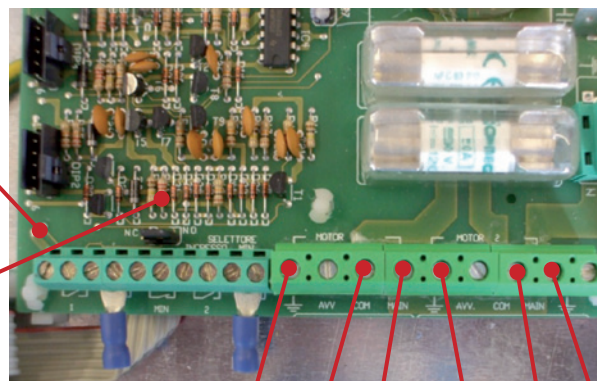

Earth Neutral Live
Pump 1

Earth Neutral Live
Pump 1

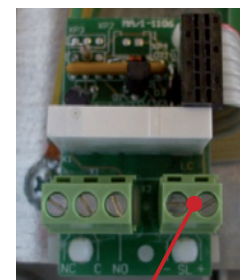

Optional high level alarm float switch inputs

Location/installation of Dipster within sump

Due to the shape of the tank a double bracket is required to fit the Dipster float switch. One or two switches can be fitted as required. The Dipster cables will be kept well out of the way of the switches by being tied to the upper bracket before being fed through the wall of the tank and into the cable conduit. The pump mains cables can be threaded from the other side.

The brackets have been sized to ensure the floats have free fall to the bottom corner of the tanks.

The central drop is fitted using the lower plate bracket and is used to fix the alarm switch.

The whole unit would be supplied fully assembled with the switches, fixing bolts (either loose or fixed in place).

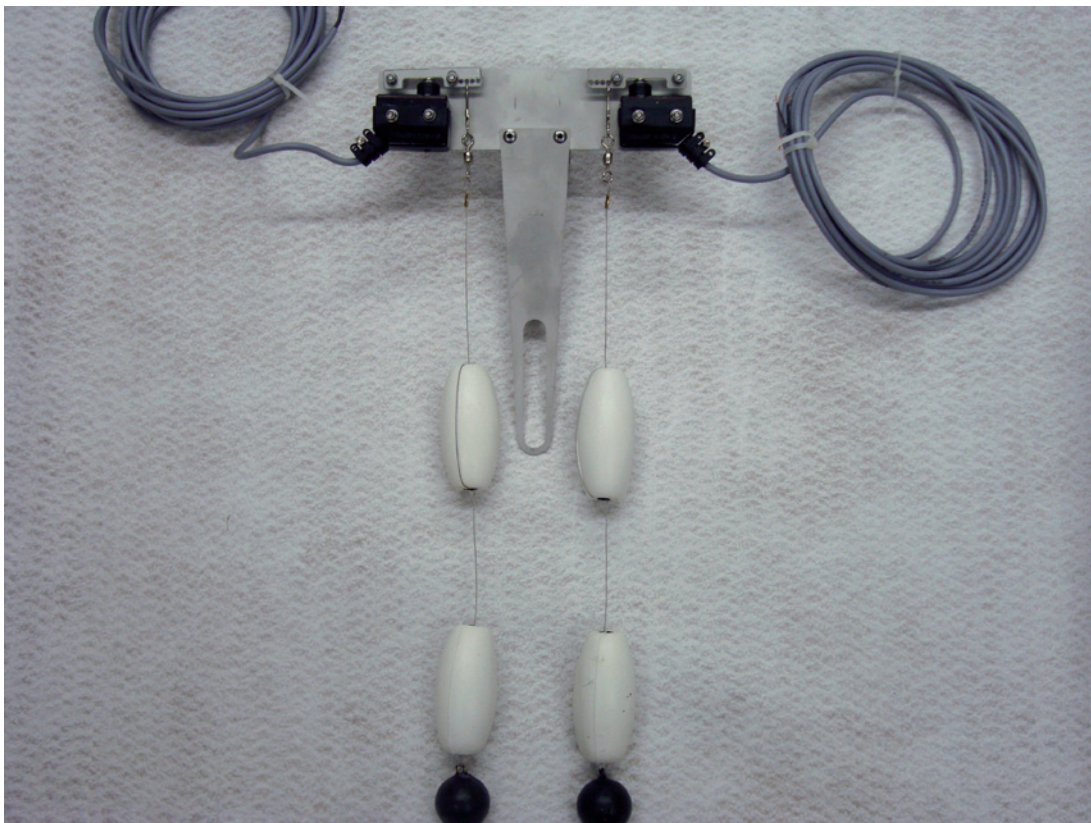
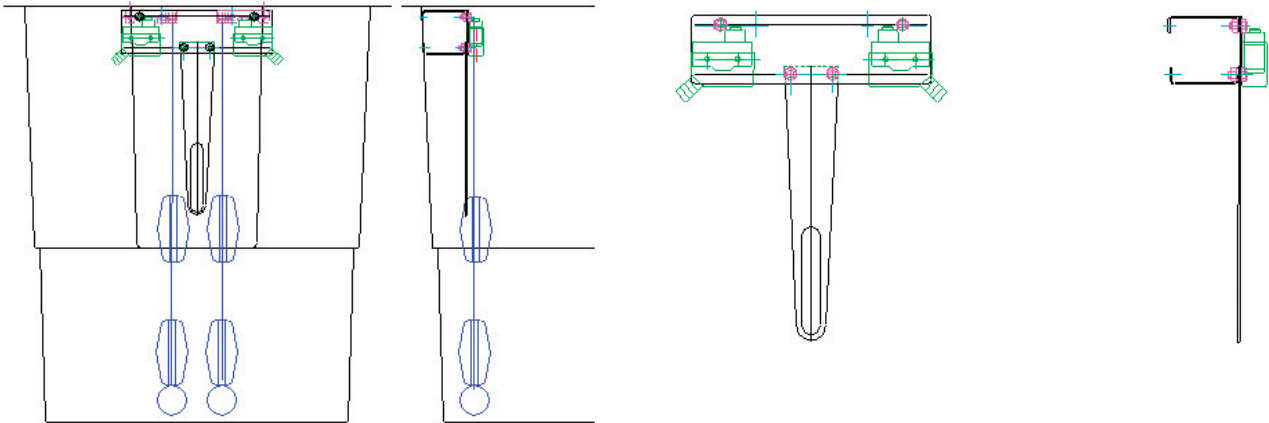

Triton Contact Details:

Triton Systems
Units 3 – 5 Crayford Commercial Centre, Greyhound Way, Crayford, Kent DA1 4HF

Tel: 01322 318830
Fax: 01322 524017
Email: info@tritonsystems.co.uk

www.tritonsystems.co.uk